



5 4 5

1/4 DIN PROCESS CONTROLLER

- ▶ Dual or Single Loop
- ▶ Cascade Control
- ▶ Ratio Control
- ▶ Feed Forward
- ▶ NEMA X Front Panel
- ▶ PowerTune®



The Interface Solution Experts
www.miinet.com

DESCRIPTION

The 545 process controller is designed to ensure the integrity of your process with maximum reliability—hour after hour, day after day. The isolated inputs and outputs guard against the dangers of electrical interference, the front face meets NEMA 4X standards for watertight operation and exposure to corrosive environments, and the solid metal housing and sturdy rubber keys enhance durability and ESD protection.

The 545 also offers a universal process input and modular, field interchangeable outputs that allow more flexibility than ever before. With two independent full feature control loops, the 545 can take the place of two PID controllers; additionally preprogrammed functions can be called for cascade, ratio and feed forward applications.

The 545 uses foreground and background loops which facilitates straightforward operator interface in any of the dual loop modes. The display allows both loop process variables and setpoints to be simultaneously displayed. The 545 also offers sophisticated control algorithms, including our exclusive PowerTune® adaptive tuner, which constantly analyzes your process and makes modifications to the tuning parameters—ensuring you're always under control.

Rugged Construction

- NEMA 4X front panel
- Thick damage resistant keys
- EMI/RFI resistance
- Input/output isolation

Operator Interface

- 3 line vacuum fluorescent display
- English prompts/messages
- Key color state indication

Tuning and Control Algorithms

- PowerTune- Adaptive tuning
- PowerTune- Pretuning
- PowerTune- Powerback anti overshoot
- 8 stored PID sets
- Multiple output algorithms

Expanded information about these strengths is detailed throughout this brochure.

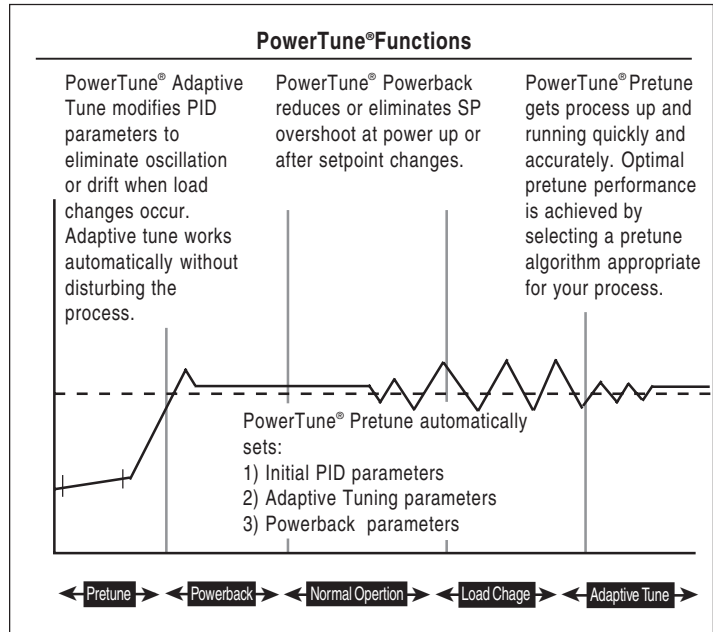

Four Field changeable output module locations (MA, Relay, SSR, DC, Logic, Loop Power)

Two Universal (U, MA, RTD, T/C) PV inputs

Option board I/O

- RSP
- 5 contact inputs
- Actuator Slideware

Optional RS 485 Communications Module

Socketed PROM

10 year lithium battery for memory retention

FEATURES

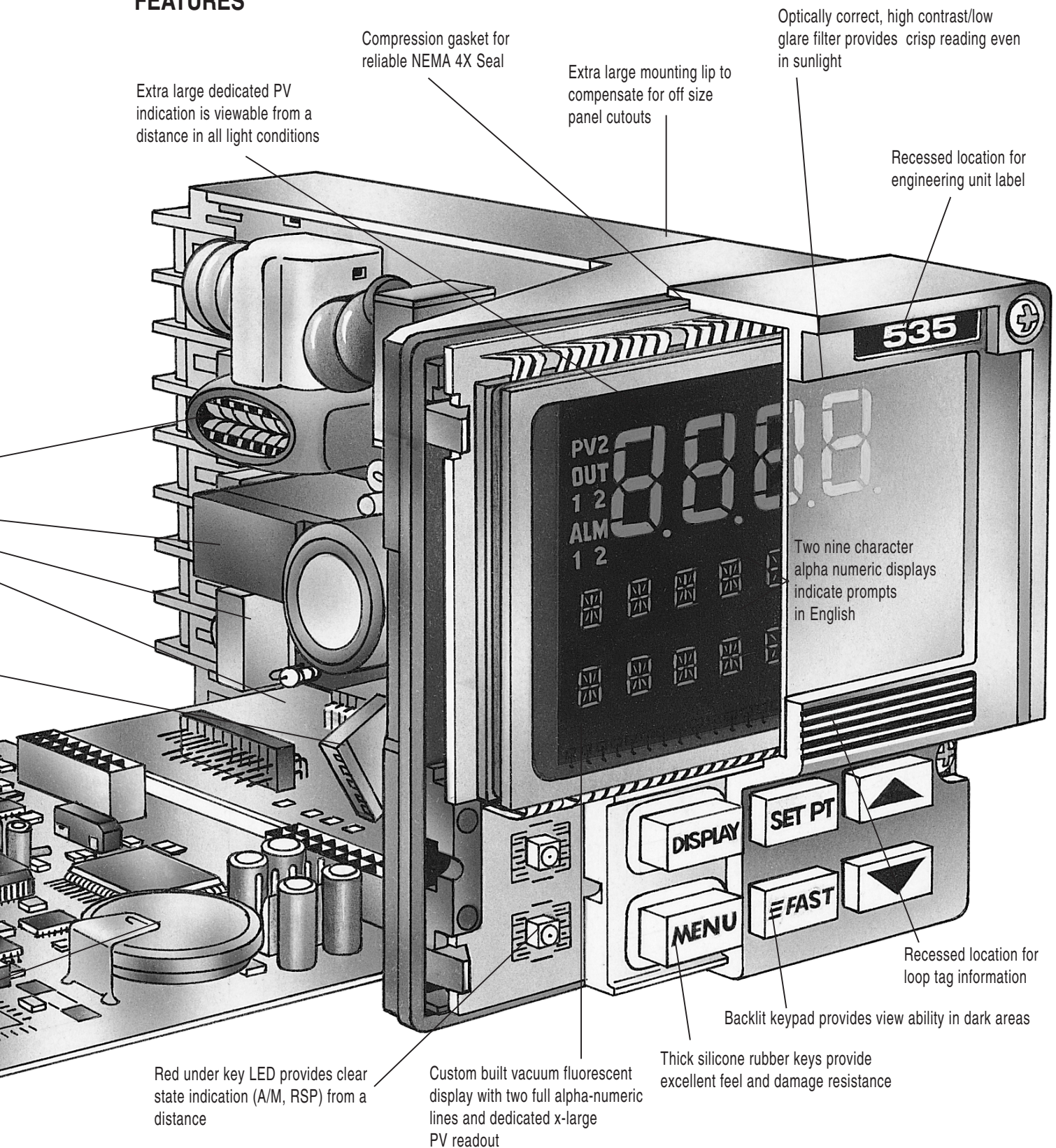

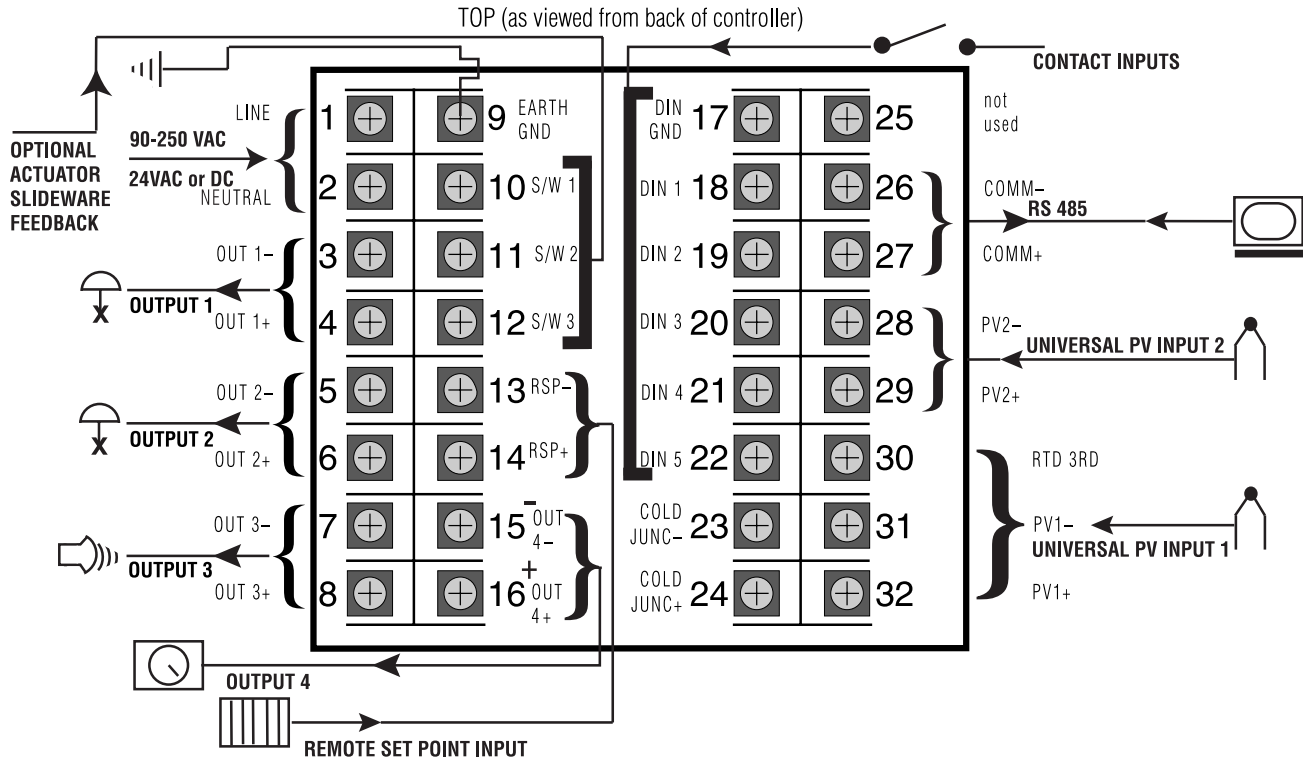

Input Functions

PV Inputs (Universal)

Thermocouples
RTD's
Voltage
Millivolt
Milliamp
User Linear Ration, 4

RSP Input (Optional)

Range
Bias
Gain
Local SP Tracking

Contact Inputs (Optional)

Activate RSP
Trip and Manual
Lock in Manual Mode
Select Alternate SP (1-8)
Select Alternate PID (1-8)
Acknowledge Alarm
Inhibit Integral Control
Invert Control Action
Inhibit Adaptive Tuning
Emulate Front Panel Keys
Digital Input for Data Acquisition

Output Functions

Outputs are plug-in modules. Types include: Analog (MA), Mechanical Relay, Solid State Relay, DC Logic, and Loop Power.

Output 1

Control

Output 2

Second Control
Alarm
Retransmission
RS 485 Driver

Output 3

Third Control
Alarm
Retransmission
RS 485 Driver
Loop Power

Output 3

Fourth Control
Alarm
Retransmission
RS 485 Driver
Loop Power

INPUT FUNCTIONS

PROCESS VARIABLE

Two universal inputs are available. Any input type may be field selected via jumper.

THERMOCOUPLES	RANGE °F	RANGE °C
B	104 to 3301	40 to 1816
E	-454 to 1832	-270 to 1000
J	-346 to 1832	-210 to 1000
K	-418 to 2500	-250 to 1371
N	-328 to 2372	-200 to 1300
R	32 to 3182	0 to 1750
S	32 to 3182	0 to 1750
T	-328 to 752	-200 to 400
W	32 to 4172	0 to 2300
W5	32 to 4172	0 to 2300
Platinel II	-148 to 2550	-100 to 1399

RTDS	RANGE °F	RANGE °C
100 ohm Pt. (DIN)	-328 to 1562	-200 to 850
	-328.0 to 545.0	-200.0 to 285.0
100 ohm Pt. (JIS)	-328 to 1202	-200 to 650
	-328.0 to 545.0	-200.0 to 285.0
100 ohm Pt. (SAMA)	-328 to 1202	-200 to 650
	-328.0 to 545.0	-200.0 to 285.0

Transmitter Signals	INPUT RANGE
Milliamps DC	4 to 20 0 to 20
Voltage DC	1 to 5 0 to 5
Millivolts DC	0 to 10 0 to 30 0 to 60 0 to 100 -25 to 25

ACCURACY

	TYPICAL (25°C)	MAXIMUM (0-50°C)
LINEAR (Voltage)	±0.025% of full scale	±0.100% of full scale
(Current)	±0.050% of full scale	±0.150% of full scale
RTD 1°	±0.050% of span	±0.150% of span
0.1°	±0.095% of span	±0.225% of span

THERMOCOUPLE

J, K, N, E (> 0°C)	±0.060% of span	±0.150% of span
J, K, N, E (< 0°C)	±0.150% of span	±0.375% of span
T (> 0°C)	±0.100% of span	±0.250% of span
T (< 0°C)	±0.250% of span	±0.625% of span
R, S (>500°C)	±0.150% of span	±0.375% of span
R, S (<500°C)	±0.375% of span	±0.925% of span
B (>500°C)	±0.150% of span	±0.375% of span
B (<500°C)	±0.500% of span	±1.000% of span
W, W5 & Platinel II	±0.125% of span	±0.325% of span

Display accuracy is ±1 digit.

LINEARIZATION

Thermocouple and RTD inputs are automatically linearized.

Transmitter inputs may be linearized with a square root function or user-definable 15-point straight line linearization function.

INPUT IMPEDENCE

Current Input: 250 ohms

Thermocouple: 10 Mohms

Voltage Input: 1 Mohm

RTDs: 10 Mohms

UPDATE RATE

Input is sampled and output updated 10 times per second. Display is updated five times per second.

TRANSMITTER LOOP POWER

Isolated 24Vdc (nominal) loop power supply is available if a loop power module is installed in an output socket not used for control. Capacity is 25mA.

INPUT SIGNAL FAILURE PROTECTION

When input is lost, output is commanded to a predetermined output (-5 to 105%). Thermocouple burnout is selectable for upscale or downscale.

INPUT FILTER

Single pole lowpass digital filter with selectable time constant from 0 to 120 seconds.

CALIBRATION

Comes fully calibrated from the factory and continuously calibrates itself for component aging due to temperature and time, except for the reference voltage. Field calibration can be easily performed in the field with a precision multimeter and thermocouple simulator. Process variable offset and gain factors are provided to correct for sensor errors.

SETPOINT SELECTION

A remote setpoint input is available. Signal is 0-20/4-20mADC or 0-5/1-5 VDC (jumper selectable). Signal may be ratioed and biased. Eight local setpoints may be stored in memory.

Setpoint selection is made via SET PT key or digital contact(s).

DIGITAL INPUTS

A set of five external dry contacts or open collector transistor driven inputs are available. Each can be configured to perform one of the following functions:

- Select remote setpoint
- Select either direct or reverse control action
- Select manual control
- Disable adaptive tuning
- Select second local setpoint
- Addressable through serial communications only
- Select a second set of PID values
- Inhibit the reset term
- Acknowledge alarms
- Lock controller in manual mode
- Simulate and keys
- Simulate DISPLAY, FAST, and MENU keys

In addition, if the set of five digital inputs is installed, four may be designated to select one of eight local setpoint (and associated PID set, if desired) via a binary coded decimal (BCD) input.

OUTPUT FUNCTIONS

OUTPUT MODULES

The controller can have a total of four control outputs, alarm outputs and/or loop power modules installed. There are five types of output modules which can be configured to suit your particular application. The modules may be ordered factory-installed, or they may be installed in the field.

Analog module: Either 0–20mA or 4–20mA (front panel selectable) into a load up to 1000 ohms. Accuracy $\pm 5\mu\text{A}$ @ 25°C.

Mechanical relay module: SPDT electromechanical relay. Resistive load rated at 5 amps at 120/240 VAC. Normally open or normally closed selection is made by jumper. Output 4 is rated at 0.5 amps at 24 VAC and is always normally open.

Solid state relay (triac) module: Resistive load rated at 1 amp at 120/240 VAC. Output 4 is rated at 0.5 amps at 24 VAC. These outputs are normally open.

DC logic (SSR drive) module: “ON” voltage is 17 Vdc (nominal). “OFF” voltage is less than 0.5 Vdc. (Current limited to 40mA.)

Loop power supply module: Current is limited to 25mA @ 24V (nominally loading).

CONTROL OUTPUTS

Up to two output modules per loop may be designated for control. Any combination of output modules, with the exception of the loop power supply module, may be used.

Duplex control is available if output modules are installed in the first and second output sockets for either loop.

Position proportioning control with feedback is available if mechanical or solid state relay modules are installed in the first two output sockets, and the slidewire feedback option is installed. The feedback option may be added in the field. Slidewire feedback range is 0 to 1050 ohms (Slidewire SP available for either loop 1 or loop 2—one loop only).

“**Velocity**” **position proportioning control** is available by installing mechanical or solid state relay modules in the first two output sockets. A special algorithm controls an electric actuator without the slidewire feedback signal.

Staged (split range) outputs are available if analog modules are installed in the first and second output sockets. This algorithm will allow the output range to be split between the two outputs.

CONTROL ALGORITHM

PID, P with manual reset, PI, PD with manual reset, and On-Off are selectable from the front panel. Duplex outputs each use the same algorithm, except On-Off may be used with PID. The PID algorithm used is non-interacting.

TUNING PARAMETERS

Proportional Band: 0.1 to 999% of input range

Integral: 1 to 9999 seconds/repeat

Derivative: 0 to 600 seconds

Manual Rest/Load Line: 0 to 100% output

Cycle Time: 0.3 to 120 seconds

On-Off Deadband: up to 15% of input range (in eng. units) Up to eight sets of PID values may be stored in memory and selected automatically, based on setpoint value, process variable value, or the corresponding local setpoint (SP1-SP-8)

Retransmission Output

Based on available outputs (any socket not used for control), up to two different variables can be simultaneously programmed for retransmission. Each precise, 16-bit resolution output may be scaled for any range. Variable selection includes: PV, SP, RAMP, SP, and OUTPUT.

Transmitter Loop Power

Isolated 24Vdc (nominal) loop power supply is available if a loop power module is installed in an output socket not used for control. Capacity is 25mA. Two or four wire transmitters can be powered.

ALARMS

The 545 controller has two software alarms. High and low alarms may be sourced to:

- Process Variable High
- Process Variable Low
- Process Variable High & Low
- Deviation from S.P.
- Band around S.P.
- Rate of Change
- Manual Control Module
- Remote S.P.
- Control Output

If an alarm is tripped, the alarm message will show, the ACK key will illuminate (if acknowledgeable) and the ALM icon will light. If the alarm is tied to the first available non-control output, the “1” below the ALM icon will light. Similarly, if the alarm is tied to the second non-control output, the “2” below the ALM will light. The availability of outputs determines how many alarms can be tied to relays.

Up to two alarm outputs are available if an associated mechanical, solid state relay or DC logic module is installed in any output socket not used for control.

Global Alarm feature allows one or more of the internal software alarms to be tied to the same single, physical output. The acknowledge key is active for alarms associated with either loop.

APPLICATIONS

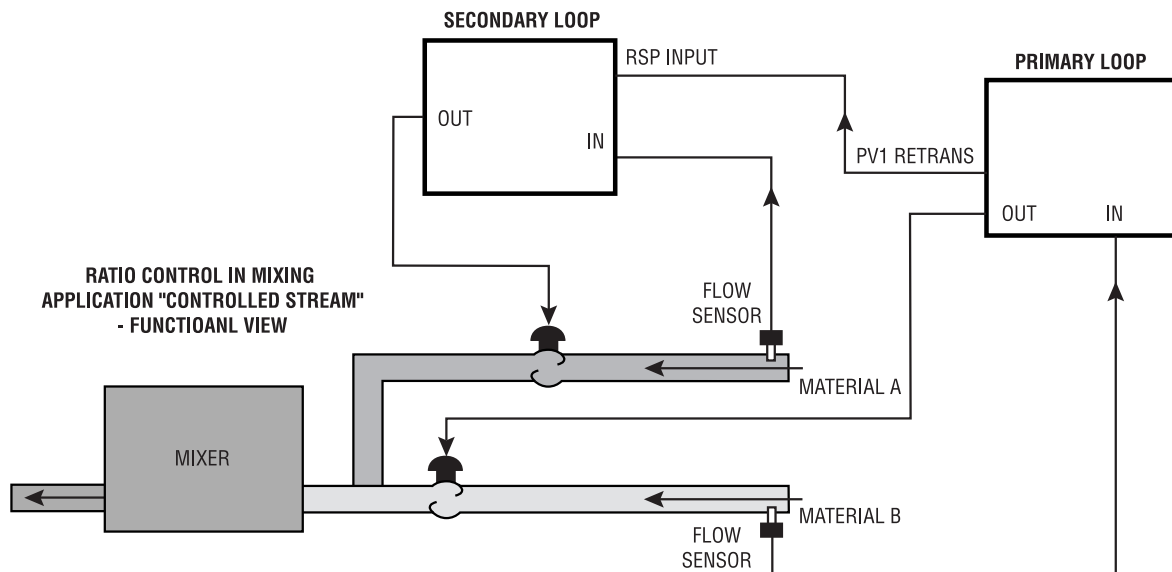
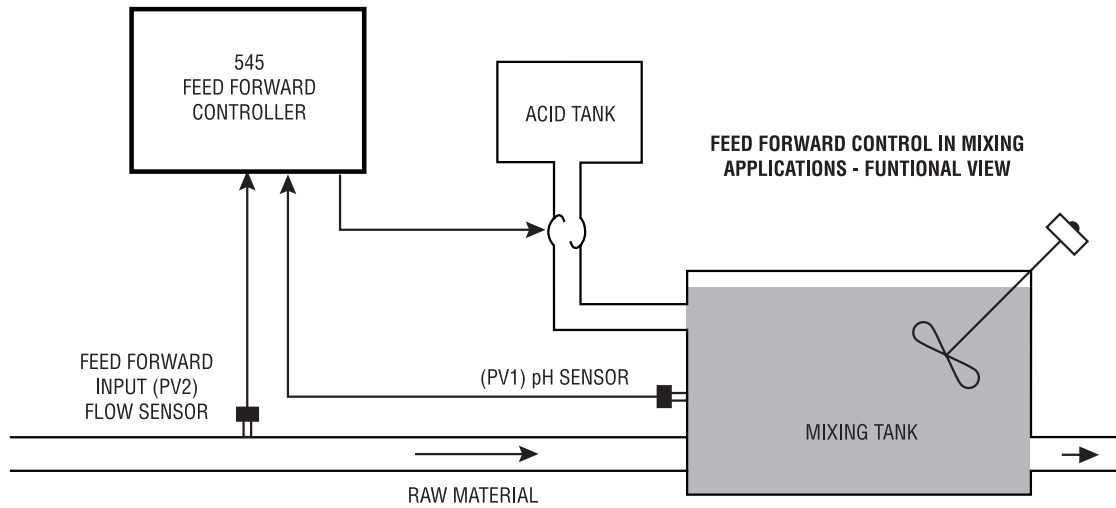
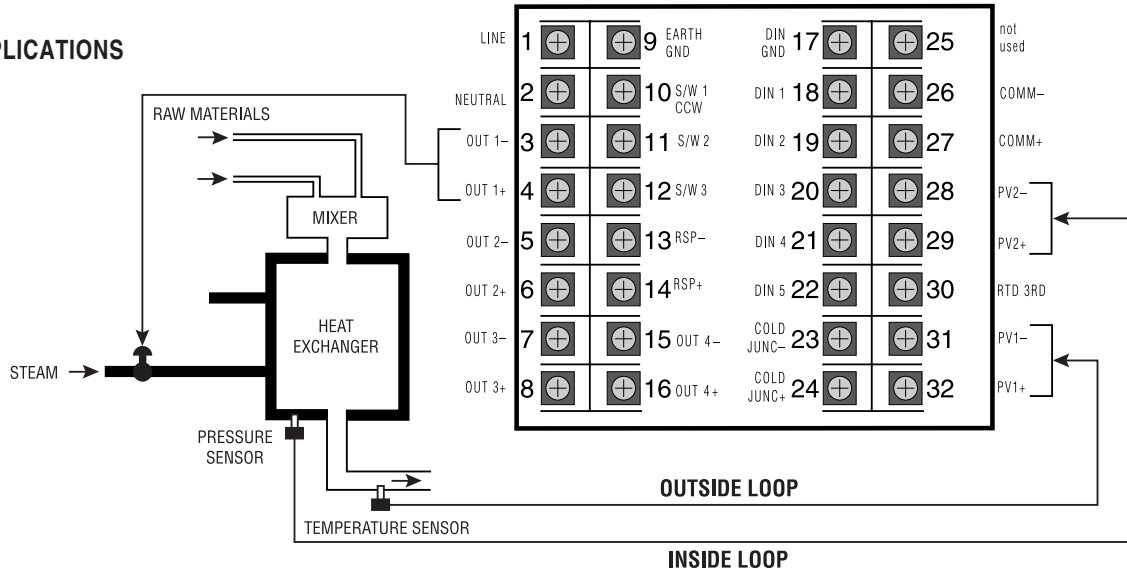

GENERAL SPECIFICATIONS

CONTROLLER ARCHITECTURE

The 545 Controller hardware can be configured as follows:

Inputs: Two universal process variable inputs are standard.

Available options include: remote setpoint, slidewire feedback and 5 digit inputs.

Outputs: Four outputs are available See Ordering Information.

RS-485 Communications: Available as option with any configuration.

SERIAL COMMUNICATIONS

Isolated serial communications is available using an RS-485 interface. Baud rates of up to 19,200 are selectable. The protocol supports CRC data checking. If communications is lost, a time-out feature will command the controller to a particular control mode and specific setpoint or output if desired. Outputs 2–4 and digital inputs can act as “host-controlled” I/O independent of the controller’s function. May be installed in the field.

DIGITAL DISPLAYS

Upper display: five-digit, seven-segment. Used exclusively for displaying the process variable value. Height is 15mm (0.6 in.).

2nd display: nine-character, 14-segment alphanumeric. Used for displaying setpoint, deviation, output value, slidewire position (actual valve position) and configuration information. Height is 6mm (0.25 in.).

3rd display: nine-character, 14-segment alphanumeric. Used for indicating which loop is displayed and for displaying alarm messages and configuration information. Height is 6mm (0.25 in.). All displays are vacuum fluorescent. Color is blue-green.

STATUS INDICATORS

There are two types of indicators: icons and illuminated keys.

ALM 1 and ALM 2 icons: alarm 1 and alarm 2 status

OUT 1 and OUT 2 icons: control output 1 and control output 2 status.

MAN key illuminated: controller is in manual control mode.

ACK key illuminated: alarm may be acknowledged.

SET PT key illuminated: setpoint other than primary local setpoint is active.

MENU key illuminated: controller is in configuration mode.

MOUNTING

Panel-mounted.

WIRING CONNECTIONS

29 screw terminals in the rear of the instrument.

POWER CONSUMPTION

15 VA at 120 VAC, 60 Hz (typical).

WEIGHT

Approximately 1 kg (2.2 lbs.).

AMBIENT TEMPERATURE

Operative Limits: 0 to 50°C (32 to 122°F).

Storage Limits: -40 to 70°C (-40 to 158°F).

RELATIVE HUMIDITY

10 to 90%, non-condensing.

VOLTAGE AND FREQUENCY

Universal power supply: 90 to 250 VAC, 48 to 62 Hz. 24V (ADC or DC power optional).

NOISE IMMUNITY

Common mode rejection (process input): >120 dB.

Normal mode rejection (process input): >80 dB.

AC line is double filtered and transient protected. Snubbers are provided for each relay output.

ISOLATION

Inputs and outputs are grouped into the following blocks:

Block 1: process variable

Block 2: outputs 1, 2, 3 and 4

Block 3: communications, set of five digital inputs

Block 4: remote setpoint

Each block is electrically isolated from the other blocks to withstand a HIPOT potential of 500 Vac for 1 minute or 600 Vac for 1 second, with the exception of blocks 1 and 4, which are not isolated, but is capable to withstand a potential of 50 volts peak for 1 minute between each other. Inputs and outputs are not isolated from other inputs and outputs within the same block.

CONSTRUCTION

Case: extruded, non-perforated black anodized aluminum with ABS plastic sleeve.

Bezel: black plastic ABS.

Chassis assembly: plug-in type.

Keys: silicone rubber with diffusion printed graphics.

NEMA rating: front panel conforms to NEMA 4X when instrument is properly installed.

AGENCY APPROVALS



SECURITY

There are two levels of access: restricted and full. A configurable code is used to enter the full access level. Functions not available in the restricted level are configurable.

MEMORY RETENTION

Lithium battery maintains all programming for approximately ten years.

